

Roll Heated Flatwork Finisher

8 inch (140 mm) Roll Models
Refer to Page 4 for Model Identification

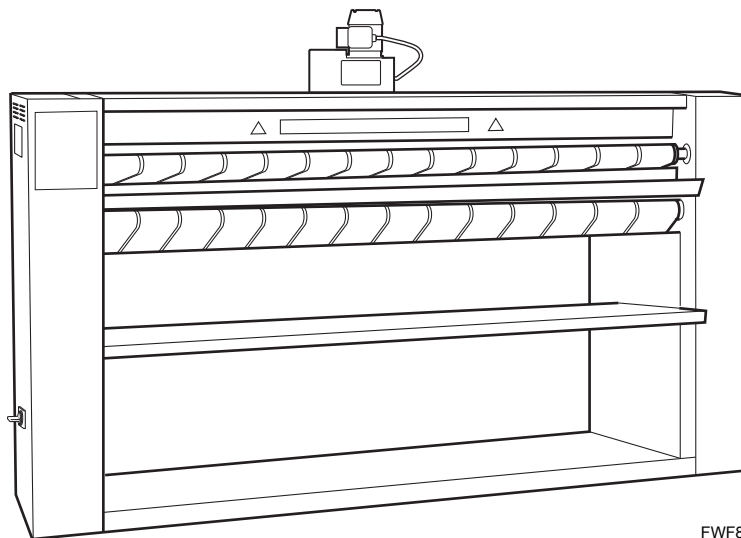

Keep These Instructions for Future Reference.

(If this machine changes ownership, this manual must accompany machine.)



Table of Contents

Introduction	3
Serial Plate Location.....	3
Replacement Parts.....	4
Customer Service.....	4
Model Identification.....	4
Safety Information	5
Explanation of Safety Messages.....	5
Safety Notice.....	8
Important Safety Instructions.....	8
Installation	10
Pre-Installation Inspection.....	10
Overall Dimensions and Connecting Data.....	11
Required Materials.....	12
Location Requirements.....	12
Lifting the Finisher.....	13
Moving the Finisher with Rollers.....	13
Electrical Requirements.....	15
Grounding Instructions.....	15
Electrical Connection.....	16
Exhaust Requirements.....	16
Exhaust System Materials.....	16
First Start-Up.....	17
Operation	19
Operating Instructions for	
Microprocessor Models Starting October 2003.....	19
Operating Controls.....	19
Pre-Operating Procedures.....	20
Operating Instructions.....	20
Operating Instructions for	
Electromechanical Models Through September 2003.....	22
Operating Controls.....	22
Pre-Operating Procedures.....	23
Operating Instructions.....	23
Regulating the Cylinder Heat.....	24
Breakdown Procedures.....	24
Alarms.....	25
Emergency Safety Bar.....	25
Thermal Warning Fan.....	25
Speed Regulator Alarm.....	25
Overheating or Sensor Not Connected.....	25
Extended Periods of Non-Use.....	25
Maintenance	26
Feeding Ribbons Tension Adjustment.....	26
Return Ribbon Tension Adjustment.....	27
Press-Roller Pressure Adjustment.....	28
Press-Roller Drive Chain Tension Adjustment.....	28
Thermostat Inspection.....	29

© Copyright 2012, Alliance Laundry Systems LLC

All rights reserved. No part of the contents of this book may be reproduced or transmitted in any form or by any means without the expressed written consent of the publisher.

Cleaning the Scrapers	29
Waxing the Ironing Cylinder	29
Removing Rust From Ironing Cylinder	30
Periodic Maintenance	30
Daily	30
Weekly	30
Every 200 Hours	30
Replacement of Feeding Ribbons	31
Replacement of Return Ribbons	33
Replacement of Supporting Rollers	35
Replacement of Side Rollers	35
Troubleshooting Undesirable Finishes	36

Introduction

Serial Plate Location

The serial plate is located on the left side panel of the finisher. Refer to *Figure 1*. Always provide the machine's serial number and model number when ordering parts or when seeking technical assistance.

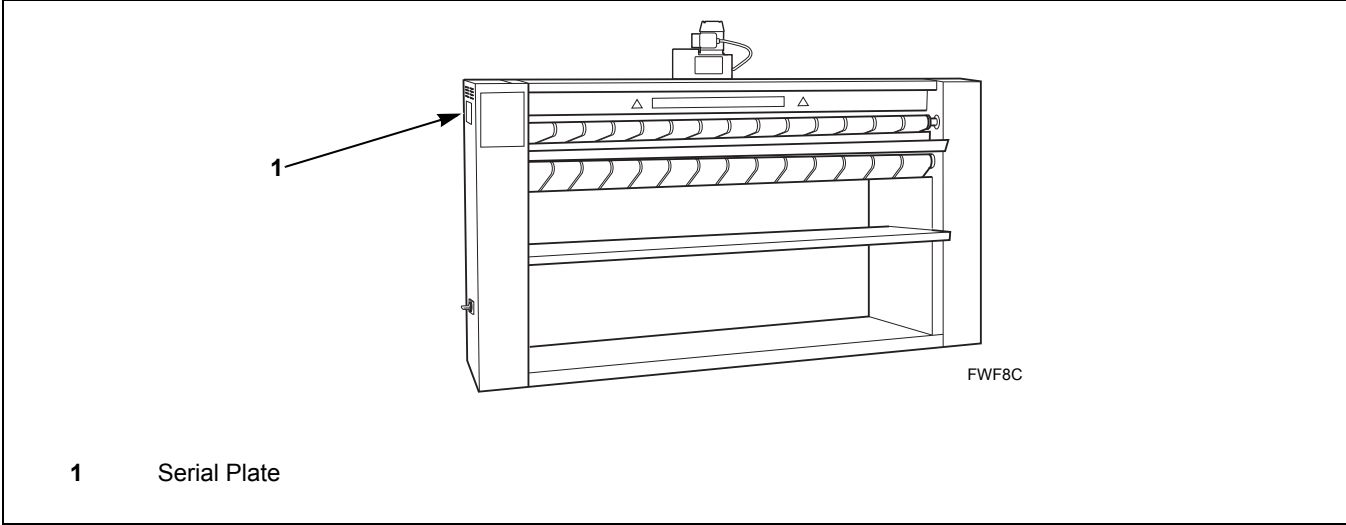

Figure 1

Introduction

Replacement Parts

If literature or replacement parts are required, contact the source from which the machine was purchased or contact Alliance Laundry Systems at (920) 748-3950 for the name and address of the nearest authorized parts distributor.

Customer Service

For technical assistance, contact your distributor or call the following number:

(920) 748-3121
Ripon, Wisconsin

Model Identification

Information in this manual is applicable to the model listed below.

UD08F055

Safety Information

Explanation of Safety Messages

Throughout this manual and on machine decals, you will find precautionary statements (“DANGER,” “WARNING,” and “CAUTION”) followed by specific instructions. These precautions are intended for the personal safety of the operator, user, servicer, and those maintaining the machine.

	DANGER
Indicates an imminently hazardous situation that, if not avoided, will cause severe personal injury or death.	

	WARNING
Indicates a hazardous situation that, if not avoided, could cause severe personal injury or death.	

	CAUTION
Indicates a hazardous situation that, if not avoided, may cause minor or moderate personal injury or property damage.	

Additional precautionary statements (“IMPORTANT” and “NOTE”) are followed by specific instructions.

IMPORTANT: The word “IMPORTANT” is used to inform the reader of specific procedures where minor machine damage will occur if the procedure is not followed.

NOTE: The word “NOTE” is used to communicate installation, operation, maintenance or servicing information that is important but not hazard related.

Safety signs and labels are also placed on the unit. Those signs and labels are limited messages. Where needed, further explanations are provided below. These signs are to be inspected for readability and replaced when missing, damaged, or unreadable. Refer to the *Maintenance* section of this manual for the periodic maintenance schedule. Refer to the parts manual for ordering information.

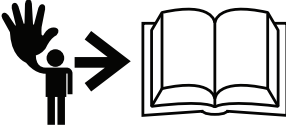
	ATTENTION
Dans le but d'éviter tous risques d'accidents, lire le manuel avant installation, utilisation, maintenance ou entretien de la machine.	
ATENCIÓN	WARNING
Para evitar todo riesgo de accidente, leer el manual antes instalación, utilización, limpieza de la maquina.	To prevent serious injury or death, read machine manuals before installing, operating, servicing or clean machine.



W811

WARNING	
Hot rollers can catch hand or clothing and cause severe injury. Immediately shut off heat and power before attempting to free jammed flatwork. Do not contact moving rolls or heated parts.	
CUIDADO	
Los rodillos calientes pueden atraparle la mano o las prendas y causar lesiones graves. Deconecte inmediatamente la calefaccion or y la electricidad antes de intentar extraer la ropa atascada. No toque los rodillos en movimiento ni las piezas calientes.	
ATTENTION	
Les rouleaux chauds peuvent attraper les mains et les vêtements et causer de sévères blessures. Stopper immédiatement le chauffage et l'énergie avant d'essayer de libérer le linge. Ne jamais être en contact avec les rouleaux en rotation ou les éléments chauds.	

W807

⚠ WARNING	
DISCONNECT POWER AND OTHER UTILITIES BEFORE SERVICING REMOVING JAMS ADJUSTING OR OTHERWISE WORKING ON THIS EQUIPMENT. DO NOT OPERATE WITHOUT GUARDS.	
	
	
⚠ CUIDADO	
DESCONECTE LA ENERGIA Y UTILIDADES ANTES DE EFECTUAR SERVICIOS. EXTRAER PRENDAS ATASCADAS. NO OPERE SIN SEGURIDADES.	
⚠ ATTENTION	
DECONNECTER L'ELECTRICITE ET AUTRE ENERGIE AVANT TOUTE INTERVENTION DE MAINTENANCE SUR CET APPAREIL. NE JAMAIS TRAVAILLER SANS LES SECURITES PREVUES SUR CETTE MACHINE.	

W808

	⚠ WARNING ⚠ AVERTISSEMENT	
<ul style="list-style-type: none"> ● This dryer-ironer must be exhausted to the outdoors. ● Exhaust ductwork should be examined and cleaned, if necessary, every three months after installation. ● Do not distort thimble when installing ductwork. Make sure thimble vanes open and close freely after ductwork has been installed. 	<ul style="list-style-type: none"> ● L'évacuation de la sècheuse doit s'effectuer vers l'extérieur. ● Après installation, le conduit d'évacuation doit être vérifié et nettoyé tous les trois mois selon besoin. ● Ne pas fausser le dispositif d'assemblage pendant l'installation du conduit d'évacuation. S'assurer que le moteur de ventilation tourne dans le bon sens (flèche du moteur). 	

W809

WARNING! HIGH VOLTAGE INSIDE DISCONNECT MAIN POWER BEFORE REMOVING COVER. ONLY SPECIALLY TRAINED PERSONNEL SHOULD TURN POWER ON WHEN COVER IS REMOVED.
ATTENTION! HAUTE TENSION A L'INTERIEUR COUPER L'ALIMENTATION ELECTRIQUE AVANT DE RETIRER CE PANNEAU. SEULEMENT UN TECHNICIEN QUALIFIE PEUT REMETTRE SOUS TENSION APRES AVOIR REMONTE CE PANNEAU.

W812



FWF136N

PUSH TO STOP IRONER
PRESIONE PARA PARAR
POUSSER POUR ARRÊTER LA MACHINE

FWF137N

ATTENTION	IMPORTANT	IMPORTANTE	ACHTUNG
<ul style="list-style-type: none"> - Utiliser impérativement toute la longueur du cylindre. Pour petites pièces, engager alternativement de gauche à droite. - Ne jamais arrêter la machine à plus de 80 degrés. Laisser refroidir en marche avant arrêt complet. - Cette machine nécessite un entretien minimum et régulier. Avant chaque utilisation, vérifier le bon contact du support soie avec le cylindre. Au maximum, toutes les 200 heures, il est impératif: <ul style="list-style-type: none"> - de nettoyer les ventilateurs, - de vérifier la propreté des conduits d'aspiration, - de graisser les chaînes, poulies et paliers, - de vérifier la tension des sangles d'engagements et de repassage. <p style="text-align: center;">Se reporter à la notice d'entretien.</p>	<ul style="list-style-type: none"> - Please use the entire length of the cylinder. For small pieces, feed alternating from the left to right. - Never stop the machine when temperature is over 80 Celsius (176 Fahrenheit). Cool down the machine before switching it off. - This machine needs minimum and regular maintenance. Before each start up check the contact between the thermostat probe heater and the cylinder. Every 200 hours of work, it is imperative to: <ul style="list-style-type: none"> - Check and clean venting. - Lubricate the chains, the pulleys and the bearings. - Check the tension of the belts on hosing belts. <p style="text-align: center;">Please read the maintenance book for complete information.</p>	<ul style="list-style-type: none"> - Utilizar toda la longitud del cilindro. Introducir las piezas pequeñas de ropa alternando de izquierda a derecha. - No parar la máquina con una temperatura superior a 80C. Enfriar la máquina antes de detenerla. - Esta máquina necesita un mantenimiento mínimo y regular. Antes de cada empleo comprobar la limpieza entre el soporte del termostato y el cilindro. Cada 200 horas de trabajo es necesario: <ul style="list-style-type: none"> - Limpiar la ventilación. - Comprobar la limpieza de los tubos de extracción. - engrasar las cadenas, poleas y rodamientos. - Comprobar la tensión de las bandas de entrada y de planchado. <p style="text-align: center;">Leer el libro de mantenimiento.</p>	<ul style="list-style-type: none"> - Bitte nutzen Sie die ganze Zylinderlänge. Für kleinen Stück, alternativ links zu rechts einstecken. - Die Maschine nie über 80C außer Betrieb setzen. Bitte die Maschine abkühlen lassen bevor stoppen. - Diese Maschine braucht regelmäßige und Mindestwartung. Vor jedem Starten, Kontakt des Temperaturfühler mit dem Zylinder prüfen. Jede 200 arbeitsstunden ist es wichtig: <ul style="list-style-type: none"> - die Entlüftungen zu reinigen, - die Düse-Abzug zu prüfen und reinigen - die Ketten, Rollen und Lager zu ölen, - den Druck von Einsatz- und Biegebändern zu prüfen. <p style="text-align: center;">Bitte die technische Beschreibung lesen.</p>

W813

ARRET D'URGENCE - STOP - EMERGENCY

FWF138N

	WARNING
<ul style="list-style-type: none"> • Failure to install, maintain, and/or operate this machine according to the manufacturer’s instructions may result in conditions which can produce serious injury, death, and/or property damage. • Do not repair or replace any part of the machine or attempt any servicing unless specifically recommended or published in this Installation/Operation Manual and that you are qualified to carry out. • Whenever ground wires are removed during servicing, these ground wires must be reconnected to ensure that the machine is properly grounded and to reduce the risk of fire, electric shock, serious injury, or death. 	
W566	

Safety Notice

CAUTION: Note for installation.

The appliance, when installed, must be electrically grounded in accordance with local codes or, in the absence of local codes, with the NATIONAL ELECTRICAL CODE, ANSI/NFPA 70, or Canadian Electrical Code, CSA C22.1.

These must be provisions for adequate ventilation air and accessibility clearances for servicing and operation.

Important Safety Instructions

Save These Instructions

	WARNING
<p>To reduce the risk of fire, electric shock, serious injury or death to persons when using your flatwork finisher, read and follow these basic precautions:</p>	
W541	

1. Read all instructions before using the finisher.
2. Refer to the *Grounding Instructions* for the proper grounding of the finisher.
3. Do not iron articles that have been previously cleaned in, washed in, soaked in, or spotted with gasoline, dry cleaning solvents, or other flammable or explosive substances as they give off vapors that could ignite or explode.
4. Do not allow children to play on or around the finisher. Close supervision of children is necessary when the finisher is used near children. This is a safety rule for all appliances.
5. Check the operation of the safety finger guard at the beginning of every shift. Operating the safety guard should stop the finisher immediately. If this safety feature is not working properly, employees must shut off the finisher and notify the supervisor. Do not operate the finisher until the safety finger guard is repaired and working properly. Be sure that all other safety features, including guards and panels, are in place before operating the finisher.
6. Never service the finisher while it is running. Never reach over, under, or behind the safety finger guard or into any area near hot surfaces or moving parts without first shutting off the finisher at the switch and power source. Follow this rule whenever working on the finisher to avoid serious injury from the finisher’s heat and/or pressure.
7. Never try to remove, adjust, or straighten jammed or linen while the finisher is running. Attempting to clear the jammed linen item can result in being caught in the linen and pulled into the finisher. If something is jammed in the finisher, turn off the power before attempting to correct the problem. Avoid contact with heated parts.
8. Protect yourself and fellow workers by making sure that everyone follows all the rules. Read and follow all safety labels and warnings. Learn all aspects of the equipment such as what is hot, which parts move, all safety shut-offs, and all emergency procedures. Do not come close to moving or heated parts. Do not wear loose clothing, sweaters, jewelry, or neck ties when near the finisher.
9. Frequent scheduled safety meetings are a must to review and update rules. If anyone is observed breaking the rules, the supervisor or manager should be notified immediately. Reporting people for rule breaking could save their lives or limbs.

10. Emergency shut-offs such as finger bars and emergency stop switches, should be painted red and clearly labeled.
11. Maintenance personnel should work in a buddy system for mutual protection when working on a finisher.
12. If in doubt, don't. Do not do anything until the supervisor or service-maintenance department has been contacted. Only qualified personnel should service the finisher.
13. Do not install or store the finisher where it will be exposed to water and/or weather.
14. Do not tamper with the controls.
15. Do not repair or replace any part of the finisher or attempt any servicing unless specifically recommended in this installation/operation manual.
16. To reduce the risk of fire, **DO NOT IRON** plastics or articles containing foam rubber or similarly textured rubber-like materials.
17. Keep area around the exhaust opening and adjacent surrounding area free from the accumulation of lint, dust, and dirt.
18. The interior of the finisher and the exhaust duct should be cleaned periodically by qualified service personnel.
19. Do not put articles soiled with vegetable or cooking oil in the finisher, as these oils may not be removed during washing. Due to the remaining oil, the fabric may catch on fire by itself.
20. To reduce the risk of fire, **DO NOT** put articles which have traces of any flammable substances such as machine oil, flammable chemicals, thinner, etc. or anything containing wax or chemicals such as in mops and cleaning cloths, or anything dry-cleaned at home with dry-cleaning solvent in the finisher.
21. **ALWAYS** disconnect the electrical power to the finisher before servicing. Disconnect power by shutting off appropriate breaker or fuse.
22. Install this finisher according to the *Installation* instructions in this manual. All connections for electrical power and grounding must comply with local codes and be made by licensed personnel when required.



WARNING

To prevent serious injury or death, read finisher manuals before installing, operating, maintaining, or cleaning the finisher.

W542

Installation

Pre-Installation Inspection

Upon delivery, visually inspect the packaging and portions of the finisher that are visible through the packaging for shipping damage.

If the package or finisher is damaged or if signs of possible damage are evident, have the carrier note the condition on the shipping papers before the shipping receipt is signed, or advise the carrier of the condition as soon as it is discovered.

IMPORTANT: Lift the box cover off the finisher and check the items listed on the packing list.

Advise the carrier of any damaged or missing articles as soon as possible. A written claim should be filed with the carrier immediately if articles are damaged or missing.

IMPORTANT: Warranty is void unless the finisher is installed according to instructions in this manual. Installation should comply with minimum specifications and requirements detailed in this manual, municipal building codes, water supply regulations, electrical wiring regulations, and any other relevant statutory regulations. Due to varied requirements, applicable local codes should be thoroughly understood and all pre-installation arranged accordingly.

	WARNING
To prevent fire, explosion, or personal injury, this finisher may only be installed, adjusted, and started up by a team of qualified technicians.	
<small>W543</small>	

It is strongly recommended that the purchaser be present during installation and the first tests.

The finisher must be installed in accordance with local and national regulations and in a well ventilated room. Refer to following sections for proper installation procedures.

Overall Dimensions and Connecting Data

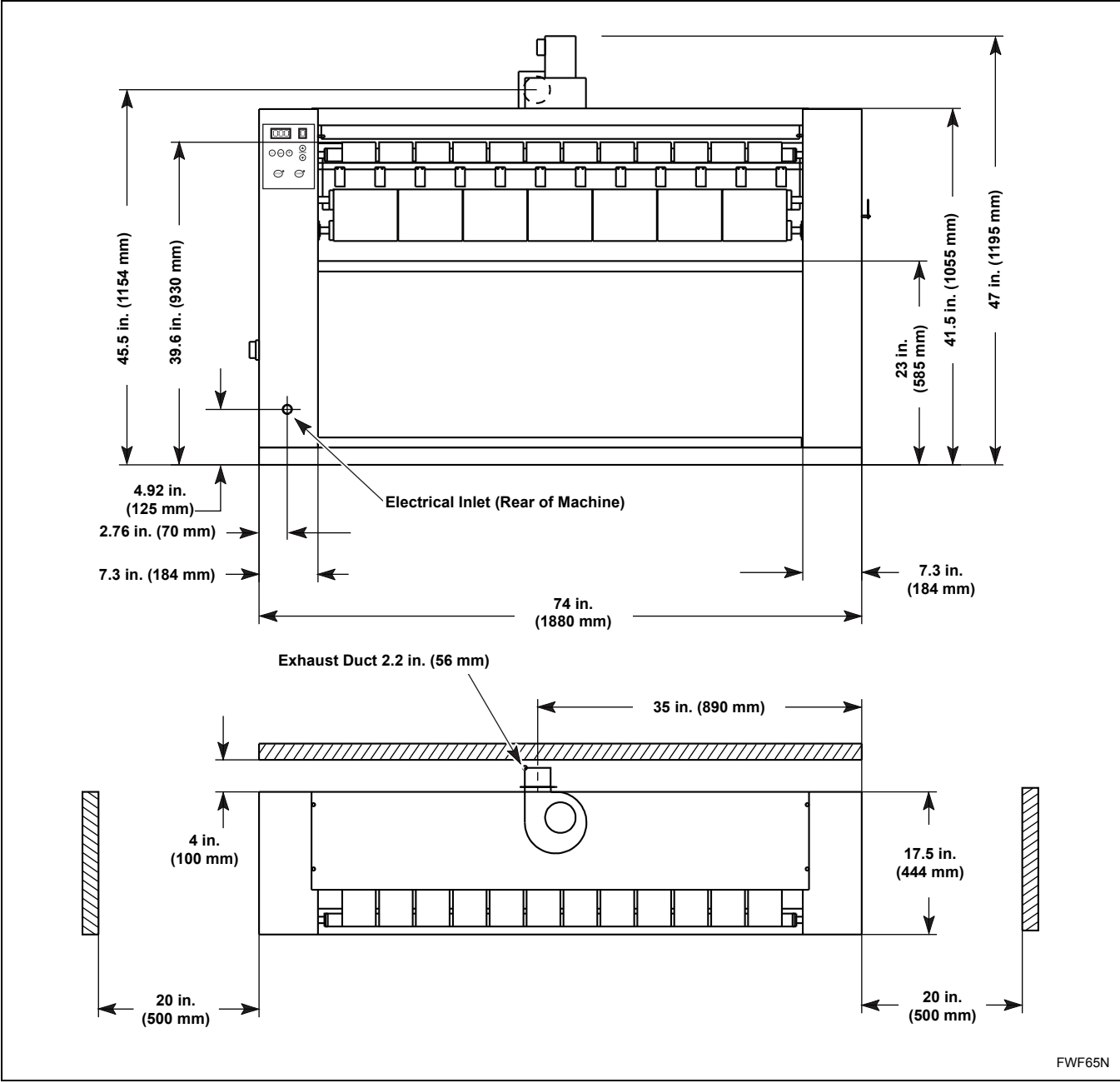

Figure 2

Weight
396 lbs. (180 kg.)

Installation

Required Materials

- One fused disconnect switch or branch circuit breaker (obtain locally)
- Pry bar
- Three 3.5 inch (89 mm) to 4 inch (102 mm) rollers or pipes

IMPORTANT: Keep finisher area clear and free from combustible materials, gasoline, and other flammable vapors and liquids.

Location Requirements

	WARNING
To prevent fire, explosion, or personal injury, this finisher may only be installed, adjusted, and started up by a team of qualified technicians.	
<small>W543</small>	

<p>This machine must be installed in compliance with all local regulations and used only in a room with adequate ventilation air. Important, read manuals before installing, operating, servicing or cleaning machine. Min clearance from both combustible and noncombustible Construction; 4" from back, 20" from side.</p> <hr/> <p>Cet appareil doit être installé conformément aux réglementations en vigueur et utilisé seulement dans un endroit bien aéré. Lire les notices avant d'installer, utiliser, entretenir ou nettoyer la machine. Espace mini entre machine et matière combustible ou non- combustible: arrière: 4", côté :20"</p>

FWF141N

IMPORTANT: Transport finisher on skid until near area of desired installation. Reasonable care should be taken during installation.

Finisher is shipped with manual crank located on tray. Be certain to keep manual crank near machine for easy access.

NOTE: With its trays removed, the finisher will fit through a 32 inch (813 mm) wide door.

To assure compliance, consult and adhere to building code requirements and comply with the following:

- The finisher must be installed in a very well ventilated room with correct lighting and an ambient temperature in the range from 32°F (0°C) to + 104°F (40°C).
- Leveling should be carried out correctly on a hard and stable floor surface, capable of supporting the weight of the finisher. The floor must at least be able to support 150 lbs./ft² (732 kg/m²) for the installation of the finisher.
- The finisher **MUST NOT** be installed or stored in an area where it will be exposed to water and/or weather.

Sufficient space must be left around the finisher to allow for its correct functioning.

- Allow at least 4 inches (102 mm) in the back to allow for ventilation.
- Allow 20 inches (508 mm) on each side for upkeep and maintenance.
- Allow sufficient space in front so that the operator can work efficiently and safely.

Lifting the Finisher

The finisher should be moved with a forklift as close as possible to the area where it will be installed. Use a forklift of sufficient capacity to lift the packaged unit according to the following procedures.

IMPORTANT: DO NOT lift finisher with slings.

1. Position the forklift arms beneath the center of the unit (NOT toward either end) to lift the finisher at its center of gravity.

IMPORTANT: Lifting the finisher from either side could cause misalignment and/or damage to the finisher.

2. Adjust the forklift arms to their maximum length and width and insert them all the way under the center of the skid. Refer to *Figure 3*.

IMPORTANT: The forklift arms must be inserted all the way under the center of the skid to avoid toppling the machine.

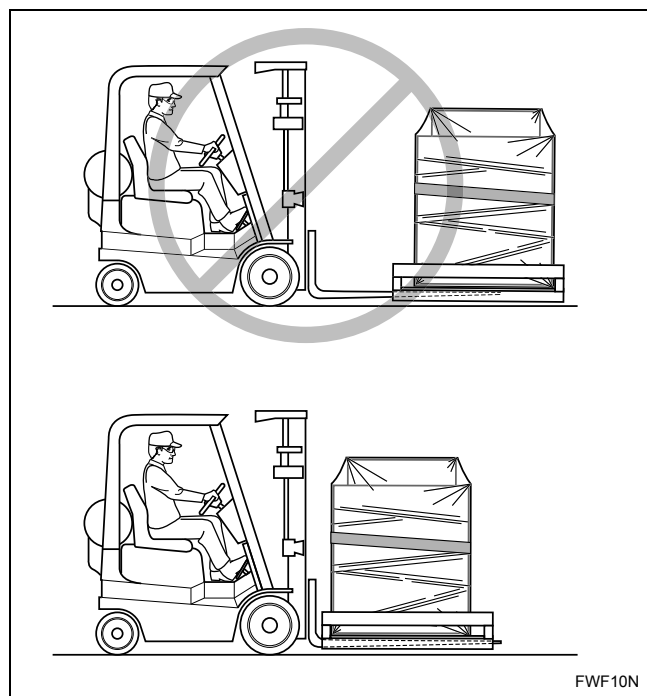

Figure 3

3. Use the forklift to carefully lift the packaged finisher. Refer to *Figure 4*.

IMPORTANT: DO NOT lift the unit more than 8 inches (203 mm) off the ground.

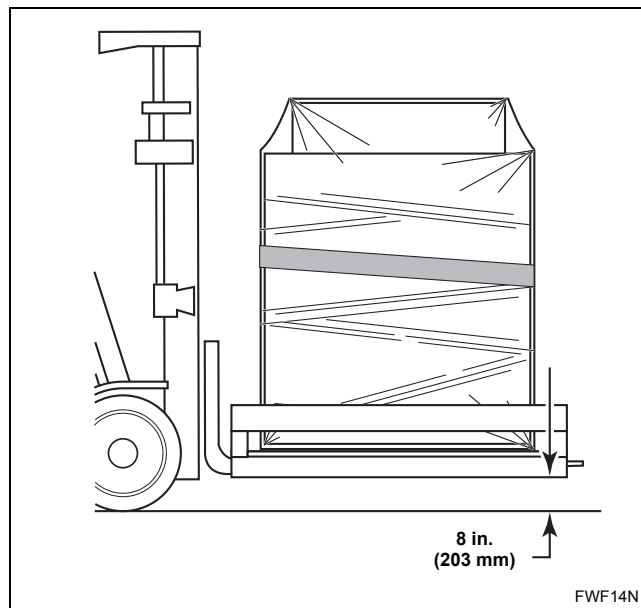

Figure 4

4. Move the packaged unit as close as possible to the area where the finisher will be installed. Follow the procedures in *Moving the Finisher with Rollers* section.

IMPORTANT: DO NOT turn the finisher over or let it drop when handling.

Moving the Finisher with Rollers

At least three people and three 3.5 inch (89 mm) to 4 inch (102 mm) rollers or pipes are required to move the finisher from the skid to its final location according to the following procedures.

IMPORTANT: At least three people are required to move the finisher. Proper lifting and handling procedures must be followed to avoid damage to the finisher.

1. Follow the procedures in *Pre-Installation Inspection* section.
2. Remove the protective packing material.

Installation

3. Use a pry bar to remove the wood stop from the skid. Refer to *Figure 5*.

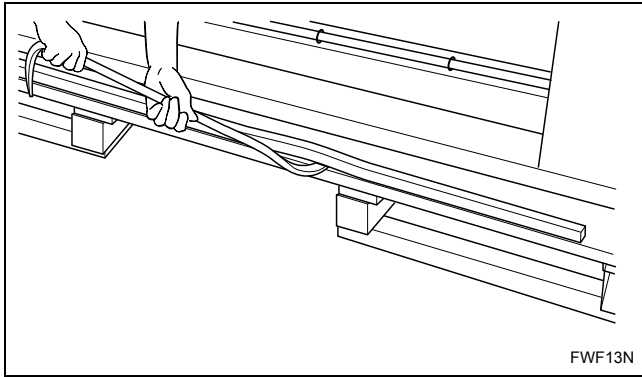

Figure 5

4. Remove the two shipping bolts from the bottom of the finisher on the inside of the side panels where they attach to the skid.
5. Place two rollers on the ground next to the finisher. Refer to *Figure 6*.
6. Place the third roller on the ground ahead of the first two rollers and past the end of the finisher.
7. Slowly lower the finisher off the skid and onto the first two rollers, exercising care to keep the unit level. Refer to *Figure 6*.

IMPORTANT: DO NOT let go of the finisher at any point in the moving process.

NOTE: If the distance between the skid and the rollers is too far to move the finisher safely onto the rollers, make another “step” by placing blocks of wood between the skid and the rollers. The wood should be level and shorter than the skid but taller than the rollers. Gradually step the finisher down onto the blocks of wood and then again onto the rollers.

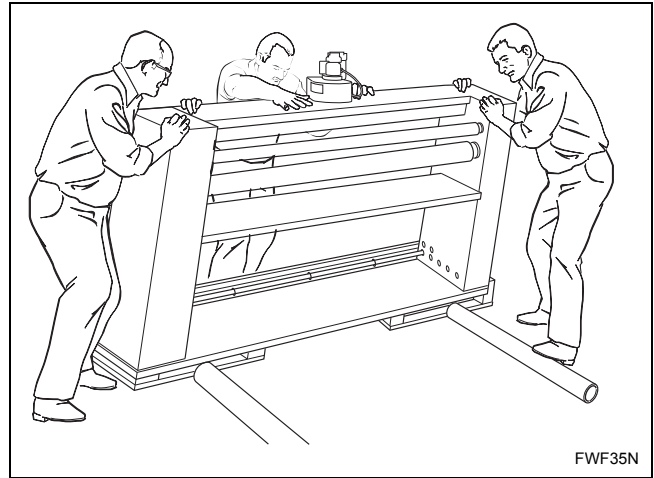

Figure 6

8. Slowly roll the finisher forward so that it comes off the first roller, stays on the second roller, and moves onto the third roller. Refer to *Figure 7*.

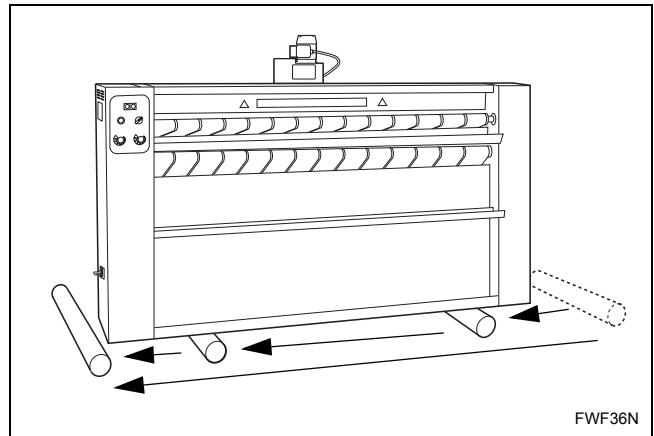



Figure 7

9. Level the finisher from right to left and front to back. Verify right to left level by checking the level of the heated roll, not the cabinet.

Electrical Requirements

	WARNING
<p>To reduce the risk of electric shock, fire, explosion, serious injury or death:</p> <ul style="list-style-type: none"> • Disconnect electric power to the flatwork finisher before servicing. • Never start the flatwork finisher with any guards/panels removed. • Whenever ground wires are removed during servicing, these ground wires must be reconnected to ensure that the flatwork finisher is properly grounded. <p style="text-align: right;">W815</p> <p>To reduce the risk of fire and electric shock, check with a qualified serviceman for proper grounding procedures. Improper connection of the equipment grounding conductor may result in a risk of electric shock.</p> <p style="text-align: right;">W068</p>	

IMPORTANT: Electrical connections must be made by a qualified electrician using data on serial plate, installation manuals and wiring diagram provided with machine and according to local electrical codes. Install a branch circuit breaker as close to the flatwork finisher as possible. If more than one flatwork finisher is being installed, a branch circuit breaker must be provided for each.

NOTE: Connect machine to an individual branch circuit not shared with lighting or other equipment.

	WARNING
<p>In case of servicing (or putting the flatwork finisher out of order), disconnect the flatwork finisher from the main supply by switching off the branch circuit breaker.</p> <p style="text-align: right;">W816R1</p>	

Grounding Instructions

NOTE: To ensure protection against shock, this flatwork finisher **MUST** be electrically grounded in accordance with the local electrical codes, or in the absence of local electrical codes, with the latest edition of the National Electrical Code ANSI/NFPA No. 70. In Canada the electrical connections are to be made in accordance with CSA C22.1 latest edition Canadian Electrical Code, or local electrical codes. Electrical work should be done by a qualified electrician.

This flatwork finisher must be grounded. In the event of malfunction or breakdown, grounding will reduce the risk of electric shock by providing a path of least resistance for electric current. This flatwork finisher must be connected to a grounded metal, permanent wiring system; or an equipment grounding conductor must be run with the circuit conductors and connected to the appropriate ground location.

	WARNING
<p>To reduce the risk of electrical shock, de-energize the electrical circuit being connected to the flatwork finisher before making any electrical connections. All electrical connections should be made by a qualified electrician. Never attempt to connect a live circuit.</p> <p style="text-align: right;">W817</p>	

	CAUTION
<p>Label all wires prior to disconnection when servicing controls. Wiring errors can cause improper and dangerous operation. Verify proper operation after servicing.</p> <p style="text-align: right;">W071</p>	

Installation

Electrical Connection

For U.S. and Canada only – **NOTE:** Branch circuit protection must be provided for the flatwork finishers and be installed in accordance with the National Electrical Code NFPA 70 (in Canada, in accordance with CSA C22.1). Please refer to the tables below for rating and supply requirements (wire size).

For CE only – **NOTE:** Adequate circuit protection must be provided for the flatwork finishers and be installed in accordance with regional electrical codes.

IMPORTANT: Electrical specifications in *Table 1* are subject to change without notice. Always refer to product serial plate for most current specifications of product being installed.

NOTE: Use copper conductors only.

NOTE: Connect to individual branch circuit breaker.

Electric Models			
Serial Plate Rating	Wire Size	Branch Circuit Breaker	Full Load Amps
208/240/60/3*	3 x 8 AWG (3 x 10 mm ²)	50	31
240/50/3+E	4 x 8 AWG (4 x 10 mm ²)	50	31
400/50/3+N+E 400/50/3+N	5 x 10 AWG (5 x 6 mm ²)	30	24

Table 1

Exhaust Requirements

	WARNING
<p>Finisher produces combustible lint. To reduce the risk of fire, the finisher must be exhausted to the outdoors.</p> <p>To reduce the risk of fire and accumulation of combustible gases, DO NOT exhaust finisher air into a window well, gas vent, chimney or enclosed, unventilated area such as an attic wall, ceiling, crawl space under a building, or concealed space of a building.</p>	
W545	

Whenever possible, install the finisher along an outside wall where duct length can be kept to a minimum and make-up air can be easily accessed.

IMPORTANT: Provisions must be made for make-up air.

The air flow necessary for combustion is 175 cfm (300 m³/m).

The exhaust outlet on the finisher has a diameter of 3.25 inches (83 mm). Using the shortest possible path, connect the exhaust outlet to an outlet duct.

IMPORTANT: Outlet ducts used for finisher's exhaust may under no circumstances be shared with other devices.

Never install flexible duct in concealed spaces, such as a wall or ceiling.

The maximum static back pressure is 1.6 W.C.I. (4 mbar).

Exhaust System Materials

Exhaust system materials are not supplied with the finisher.

Exhaust duct must be four inches (102 mm) in diameter having no obstructions. Rigid metal duct is recommended. **Do not use** plastic pipe or flexible plastic pipe, because it contributes to poor drying performance and collects lint, which can lead to a fire hazard.

DO NOT use sheet metal screws on exhaust pipe joints or other fastening means which extend into the duct that could catch lint and reduce the efficiency of the exhaust system. Secure all joints with duct tape.

First Start-Up

- 1. Verify that the finisher is stable and level. Use the heated roll to check level, not the cabinet.
- 2. Check that all connections and exhausts are correctly established.
- 3. Check that the finisher is properly grounded.
- 4. Remove wax paper from cylinder, if applicable.
 - a. Remove protective paper from below feeding table. Refer to *Figure 8*.

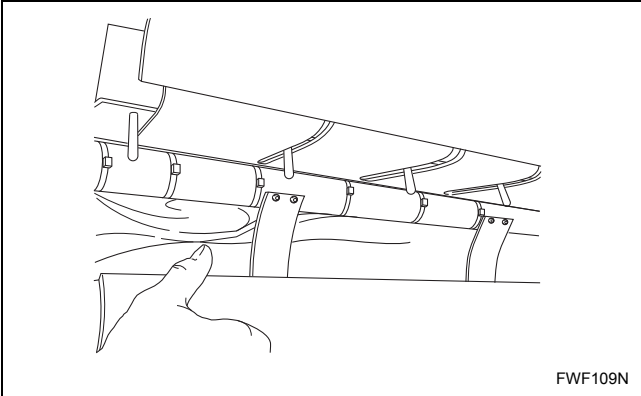

Figure 8

- b. Remove protective paper manually. Be especially careful around separation blade and temperature sensor. Refer to *Figure 9*, *Figure 10* and *Figure 11*.

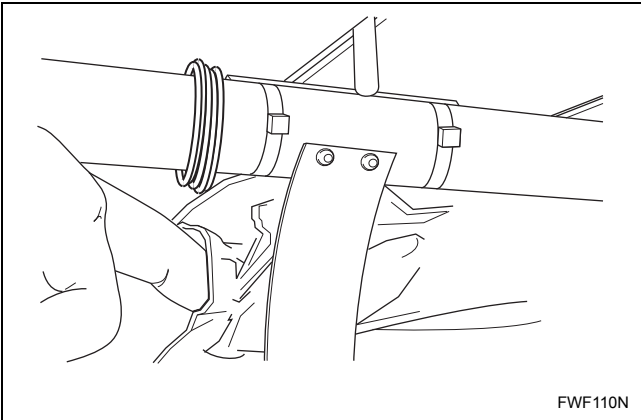

Figure 9

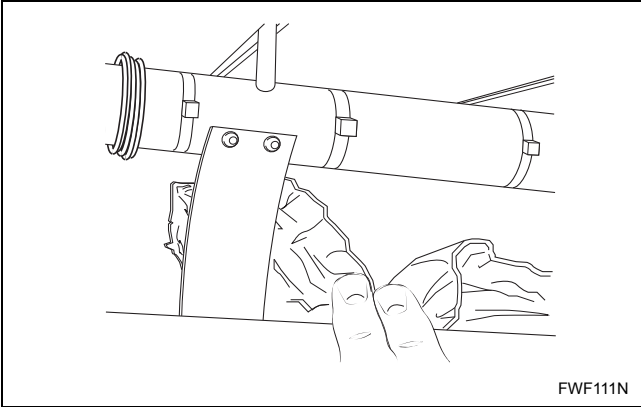

Figure 10

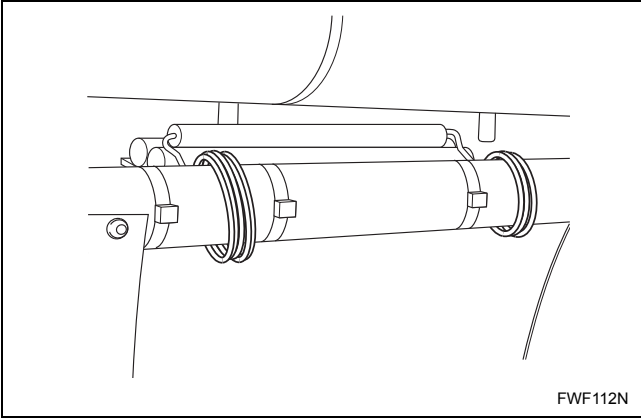

Figure 11

- c. Turn roll with crank handle. Refer to *Figure 12*.

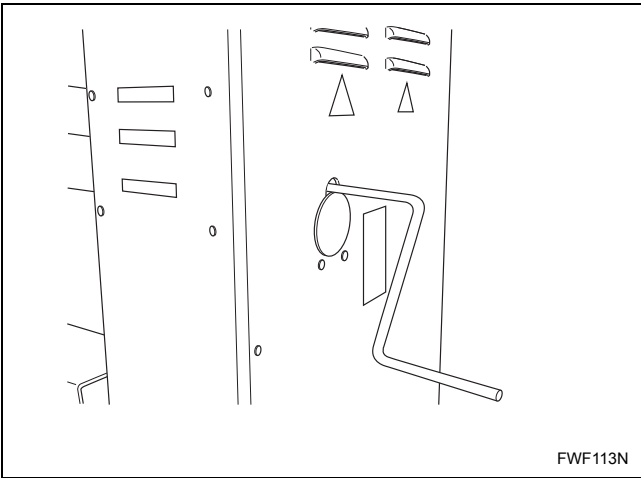

Figure 12

Installation

- d. Guide protective paper out of machine. Refer to *Figure 13*.

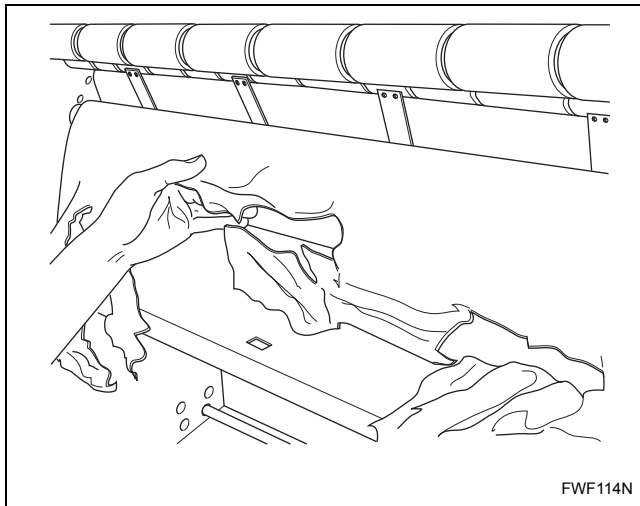

Figure 13

- e. Completely remove protective paper. Refer to *Figure 14*.

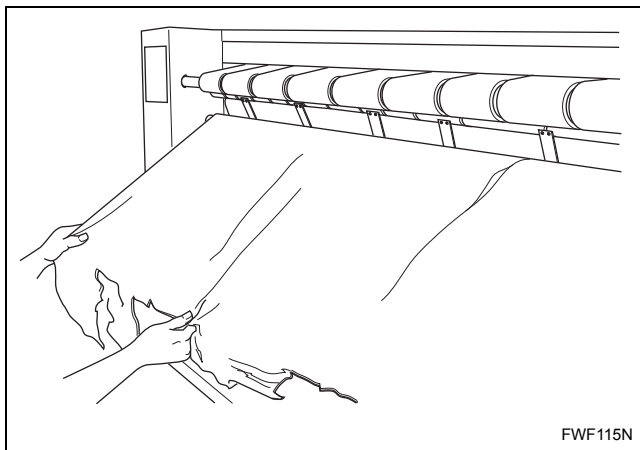

Figure 14

5. Inspect thermostat holder and make sure it is touching the cylinder. Refer to ***Thermostat Inspection*** section.
6. Check that all controls are in position 0 (OFF) and that the speed regulator knob is set to the minimum position.
7. Turn the circuit breaker to position 1 (ON).
8. On electromechanical models, press the green Power On button and hold for 1 to 2 seconds.
On microprocessor models, press START keypad.

9. For 3-phase models only, check that the exhaust fan is rotating in the direction indicated by the arrow shown on the fan. If exhaust fan is rotating in wrong direction, the electrical connection at L1, L2 or L3 terminals must be changed.

IMPORTANT: Finisher will not heat if exhaust fan is not rotating in proper direction.

10. Check that the feeding ribbons are rotating in the direction toward the interior of the finisher.

IMPORTANT: Take care not to touch or go near a moving part.

11. Place all panels back on the finisher.
12. Turn the heat switch to position 1 (ON).
13. Check that the temperature of the finisher rises.
14. Adjust the temperature selection knob according to the type of fabric and dampness level of the material being ironed.
15. When the ironing cylinder reaches the selected temperature and the heat indicator light turns off, proceed to perform an ironing test.

NOTE: The cylinder is coated with wax when leaving the factory, so perform a first ironing test using worn linen.

16. Place the worn linen flat on the input tray and allow it to be pulled into the finisher by the feeding ribbons.
17. Adjust the speed by turning the speed regulator knob left to reduce speed or right to increase speed.
18. Make sure that the sample linen comes out completely dry and with a perfect sheen. If it doesn't, either increase the temperature or reduce the ironing speed.

Operation

Operating Instructions for Microprocessor Models Starting October 2003

Operating Controls

	WARNING
<p>To avoid serious injury BEFORE operating flatwork finisher, ALL personnel MUST be trained on safe operation.</p>	
W546	

	WARNING
<p>To avoid possible serious injury, ALWAYS read and become familiar with operating instructions before operating flatwork finisher.</p>	
W547	

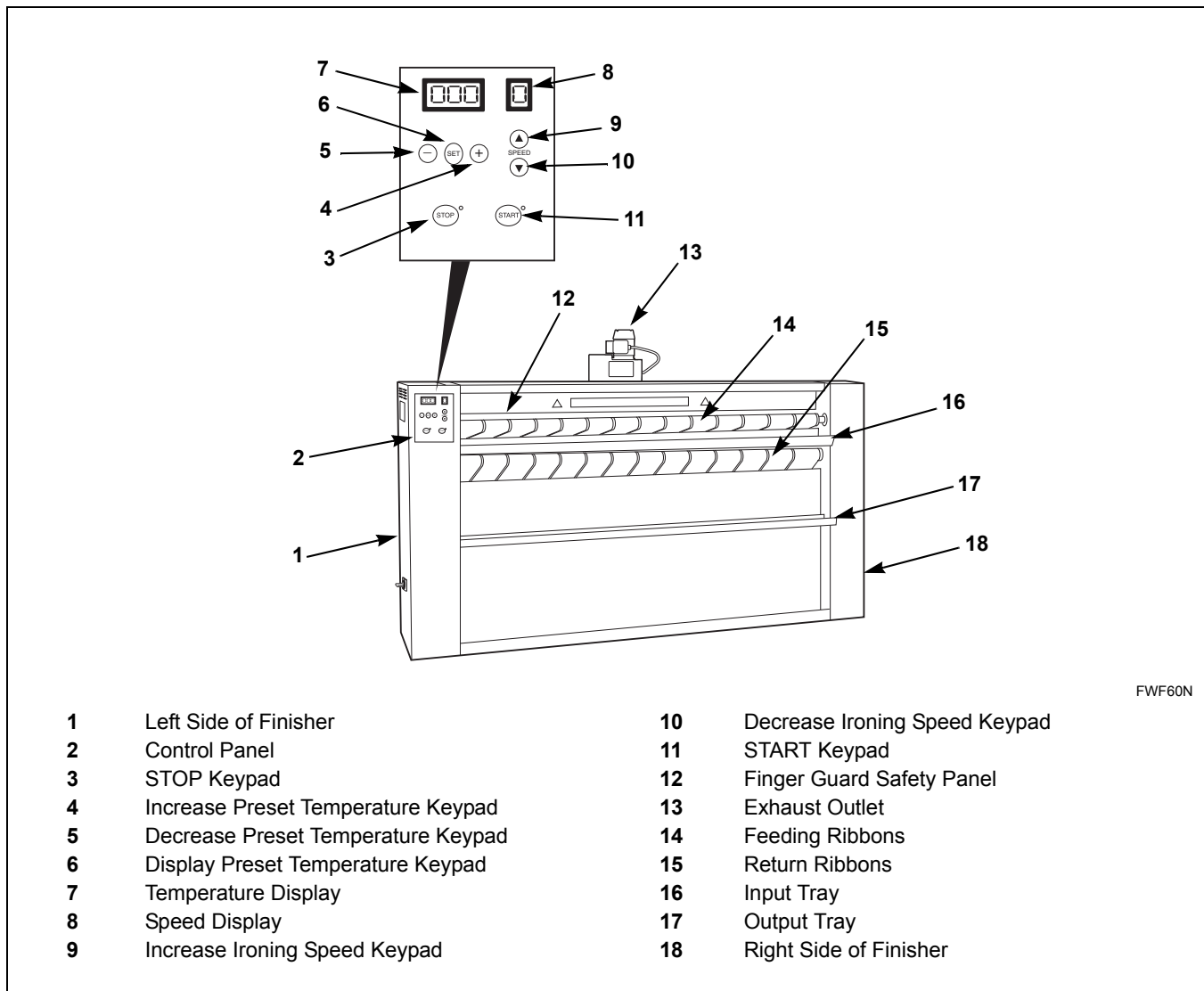

Figure 15

Operation

Pre-Operating Procedures

NOTE: All maintenance must always be carried out when the machine is stopped, the cylinder is cold, and the circuit breaker is turned off.

Perform the following procedures daily before starting the finisher.

1. Inspect the area between the thermostat and the cylinder by gently pressing on the thermostat holder so the thermostat lifts up.
2. Clean area if debris is present.
3. Check that the thermostat holder touches the cylinder.

Operating Instructions

To identify the finisher's controls, refer to *Figure 15*.

IMPORTANT: The flatwork finishers are for professional use and must be operated by qualified personnel.

1. Perform Pre-Operating Procedures.
2. Press START keypad. Indicators will light, current temperature and preset speed will be displayed, blower fan starts, cylinder rotates, and after 15 seconds, the finisher will begin to heat.
3. Check that the feeding ribbons are rotating in direction toward interior of finisher.
4. Check the operation of the finger guard safety panel by touching the panel. If finisher does not stop, press STOP keypad, discontinue use and call a qualified service person.
5. Press START keypad.
6. Choose an ironing speed between 1 and 7 by pressing either the increase ironing speed or decrease ironing speed keypads. The current speed is displayed in the speed display. The current speed does not need to be reset after power failure.

When finisher is started, if the preset speed is set between 1 and 7, the cylinder will rotate at speed 1, regardless of the preset speed, while the detected temperature remains below the preheat operating temperature (266°F [130°C] by default). Once the preheat operating temperature has been reached, the preset speed will be activated. If the temperature drops below the preheat operating temperature during operation, the speed will readjust to speed 1.

NOTE: To perfectly dry and put sheen on the laundry, the speed must be adjusted according to the type of fabric and dampness level of the material being ironed.

7. View preset temperature by pressing SET keypad. Adjust temperature by pressing increase preset temperature keypad or decrease preset temperature keypad according to the type of fabric and dampness level of the material being ironed. The new temperature is stored after three seconds.

Temperature display will then display current temperature. The maximum temperature value is established by the manufacturer.

NOTE: The heat will turn on and off while finisher is heating.

8. View temperature display. For best performance, begin ironing 5° before preset temperature is reached (for example, if preset temperature is 350°F [176°C], begin ironing at 345°F [173°C]). Refer to **Heating** section for information on heating the cylinder.

IMPORTANT: The working temperature varies depending on the fabric being ironed but must never exceed a constant temperature of 356°F (180°C).

9. Place the linen flat on the input tray and allow it to be automatically pulled into the finisher by the feeding ribbons. Refer to **Maintenance** section for information on adjusting tension of the feeding and return ribbons.
10. When the work is almost completed, press the STOP keypad. Finisher will stop automatically when the temperature of the cylinder is less or equal to the programmed stop temperature (default is 176°F [80°C]).

IMPORTANT: Never remove power from the machine when the temperature is equal to or higher than 176°F (80°C). This may cause damage to the feeding and return ribbons. Refer to *Breakdown Procedures* section for steps required when power failure occurs.

IMPORTANT: When ironing smaller sized articles, make sure to work along the length of the finisher, maintaining a consistent usage of each of the return ribbons. Doing this will prolong the life of the return ribbons.

11. Remove the finished linen from the output tray.
12. Hang or fold ironed linen as soon as possible to preserve finish.

IMPORTANT: Do not leave damp linen in the finisher as this will cause the cylinder to rust.

Operating Instructions for Electromechanical Models Through September 2003

Operating Controls

	WARNING
<p>To avoid serious injury BEFORE operating flatwork finisher, ALL personnel MUST be trained on safe operation.</p>	
W546	

	WARNING
<p>To avoid possible serious injury, ALWAYS read and become familiar with operating instructions before operating flatwork finisher.</p>	
W547	

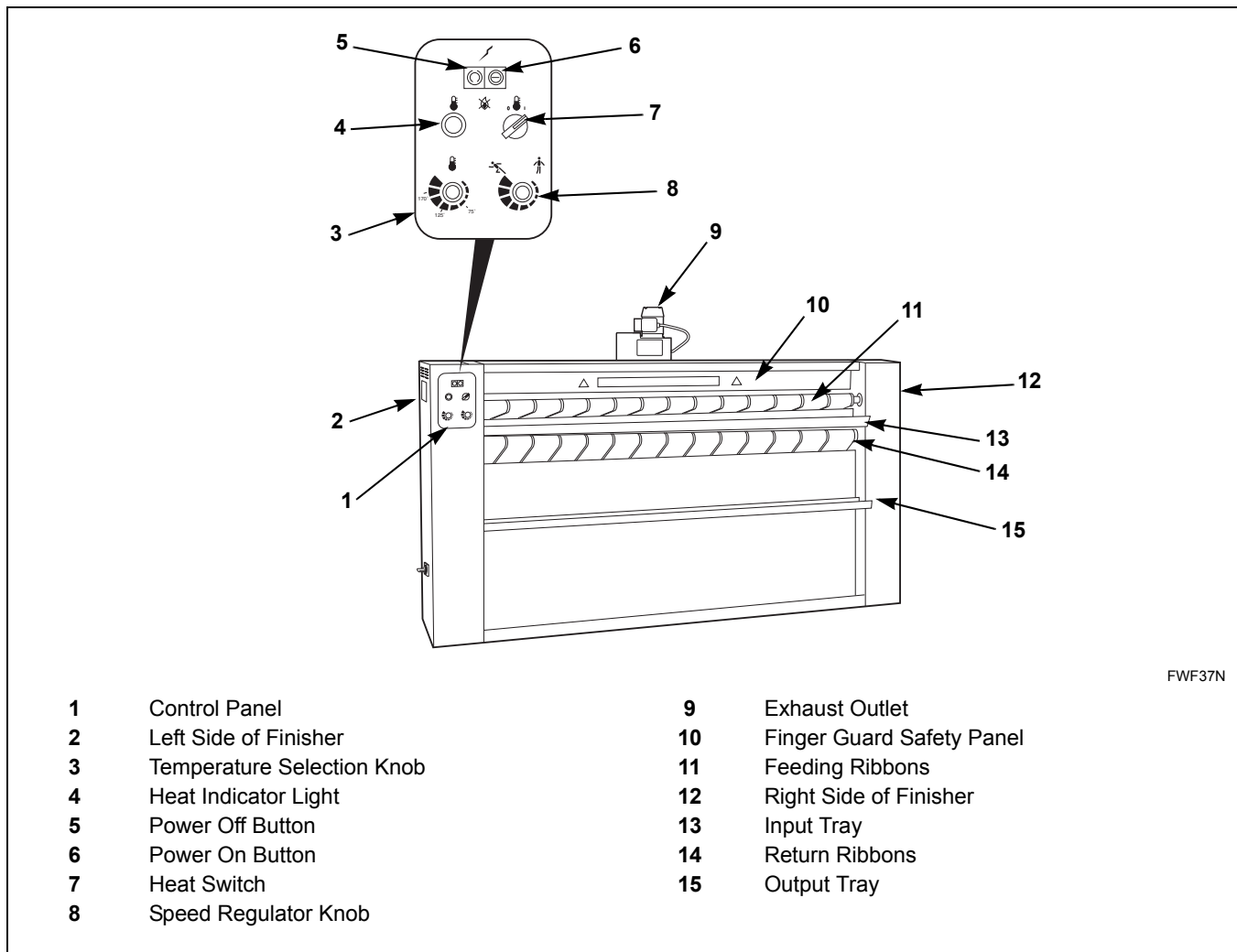

Figure 16

Pre-Operating Procedures

NOTE: All maintenance must always be carried out when the machine is stopped, the cylinder is cold, and the circuit breaker is turned off.

Perform the following procedures daily before starting the finisher:

1. Inspect the area between the thermostat and the cylinder by gently pressing on the thermostat holder so the thermostat lifts up.
2. Clean area if debris is present.
3. Check that the thermostat holder touches the cylinder.

Operating Instructions

To identify the finisher's controls, refer to *Figure 16*.

IMPORTANT: The flatwork finishers are for professional use and must be operated by qualified personnel.

1. Perform Pre-Operating Procedures.
2. Check that all controls are in position 0 (OFF), and that the speed regulator knob is set to the minimum position.
3. Turn the circuit breaker to position 1 (ON).
4. Press the green Power On button and hold down for 1 to 2 seconds.
5. Check that the feeding ribbons are rotating in direction toward interior of finisher.
6. Check the operation of the finger guard safety panel by touching the panel. If finisher does not stop, press Power Off button, discontinue use and call a qualified service person.
7. Press the green Power On button and hold down for 1 to 2 seconds.
8. Turn the heat switch to position 1 (ON).
9. Adjust the temperature selection knob according to the type of fabric and dampness level of the material being ironed.
 - Mark 1: from 212°F (100°C) to 266°F (130°C)
 - Mark 2: from 266°F (130°C) to 320°F (160°C)
 - Mark 3: from 320°F (160°C) to 356°F (180°C)
10. Wait until the ironing cylinder reaches a temperature close to the selected temperature. The heat indicator light turns off when the required temperature is reached.

IMPORTANT: The working temperature varies depending on the fabric being ironed but must never exceed a constant temperature of 356°F (180°C).

11. Place the linen flat on the input tray and allow it to be automatically pulled into the finisher by the feeding ribbons. Refer to *Maintenance* section for information on adjusting tension of the feeding and return ribbons.
12. Turn the speed regulator knob left to reduce speed or right to increase speed.
 - Left = Reduce Speed
 - Right = Increase Speed

NOTE: To perfectly dry and put sheen on the laundry, the speed must be adjusted according to the type of fabric and dampness level of the material being ironed.

13. When the work is almost completed, turn the heat switch to position O (OFF) about 20 minutes before finishing ironing to allow the cylinder to cool gradually. Once the ironing has been completed, allow the finisher to continue to run for about 20 to 30 minutes to allow to dry.

IMPORTANT: Never stop the machine when the temperature is equal to or higher than 176°F (80°C). This may cause damage to the feeding and return ribbons.

IMPORTANT: When ironing smaller sized articles, make sure to work along the length of the finisher, maintaining a consistent usage of each of the return ribbons. Doing this will prolong the life of the return ribbons.

14. Remove the finished linen from the output tray.
15. Hang or fold ironed linen as soon as possible to preserve finish.

IMPORTANT: Do not leave damp linen in the finisher, as this will cause the cylinder to rust.

16. Press the red Power Off button to shut down the finisher.

Operation

Regulating the Cylinder Heat

To heat the cylinder, the current is modified through one or two groups of resistors controlled by the heating switches.

Heating by one resistor group

When the finisher is set up to work with one resistor group, a special control function for closing and opening the heating relay switch around the set point is activated. When activated, the cylinder is able to reach and maintain the preset temperature and thermal overshoot is avoided.

When heating is activated, the decimal point on the temperature display lights up.

Heating by two resistor groups

When the finisher is set up to work with two resistor groups, the temperature is regulated by the first group as described above, while the second resistor group operates continuously when the cylinder temperature is less than the preset temperature. The second resistor turns off when the preset temperature is reached.

When heating is activated, the decimal point on the temperature display lights up. When only one resistor group is activated, the decimal point will blink.

Breakdown Procedures

Hot Finisher Stops Due to Power Failure

To separate the return ribbons from cylinder immediately:

1. Insert the crank into the opening located on the right panel of the finisher.
2. Turn the crank clockwise to rotate the cylinder. Refer to *Figure 17*.
3. Insert a thick and very wet cloth (hardly wrung dry) into the finisher while rotating the cylinder with the crank.

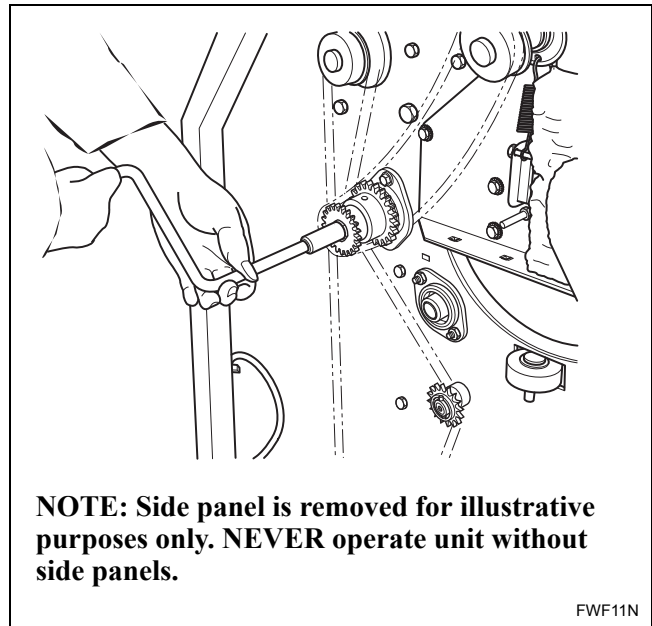

Figure 17

Finisher Won't Start or Stops Suddenly

If the finisher won't start and the cylinder won't rotate or has stopped suddenly, check if finger guard safety panels or manual crank safety switch are activated. Release the activated emergency stops, and immediately start the finisher again by pressing the green Power On button to prevent damage to return ribbons.

Unusual Noises and Other Issues

If the finisher makes unusual noises (rubbing, banging, etc.), or for any other problem contact a qualified service person immediately.

Alarms

(Microprocessor Models Only)

An alarm will sound for abnormal conditions as shown below.

Emergency Safety Bar

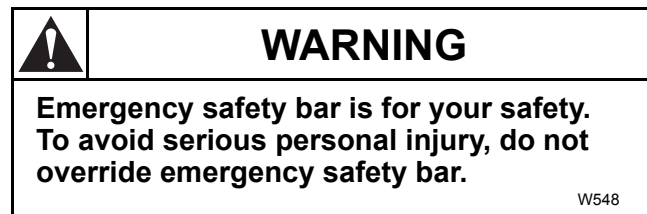

Non-CE Models

When the emergency safety bar is activated, the finisher automatically turns off and no message is displayed.

Alarm is cancelled by moving emergency safety bar to normal position and restarting finisher.

CE Models

When the emergency safety bar is activated, the finisher automatically turns off, the alarm sounds for one minute and display shows AL2.

Alarm is cancelled by moving emergency safety bar to normal position and restarting finisher or turning machine off and on.

Thermal Warning Fan

When the thermal relay of the fan is activated, the alarm sounds for one minute and display shows AL4. The fan and heating are switched off and finisher remains on. This alarm is usually caused by dirt on the fan.

Alarm is automatically cancelled when the thermal relay is closed or finisher is turned off.

Speed Regulator Alarm

When the speed regulator alarm is activated, the alarm sounds for one minute and display shows AL5.

Finisher will automatically turn off. This fault condition may be due to an overload of the cylinder motor caused by a thick object inside the finisher or by dirt in the cylinder motor. Alarm is cancelled by restarting finisher or turning finisher on and off.

Overheating or Sensor Not Connected

If the temperature sensor is broken, not connected or if sensor detects a temperature above 410°F (210°C) continuously for two seconds, the alarm sounds for one minute and display shows AL7. The finisher will continue to operate. Alarm can be cancelled by turning finisher off.

Extended Periods of Non-Use

Any time the finisher will not be used for more than a week, the cylinder must be coated with a paraffin wax layer to prevent corrosion. Refer to **Maintenance** section for information on waxing the cylinder.

Maintenance

NOTE: SHUTDOWNS due to unscheduled maintenance can be **AVOIDED** or **MINIMIZED** by:

- Performing periodic inspections as described and
- Performing lubrication services at the time intervals specified in these instructions.

Following are recommended precautions that personnel must understand and apply when performing general periodic maintenance tasks.

	WARNING
<p>To avoid possible serious injury:</p> <ul style="list-style-type: none">• ALWAYS shut off services to finisher BEFORE doing ANY maintenance, service, setup, adjustments or repair to finisher.• Shut off AND lock out ALL electric power to finisher.• Let heated surfaces cool.• BE SURE moving parts are at a standstill.• ALWAYS be careful to AVOID spring loaded components when working inside finisher. <p>ALL maintenance, service, etc. MUST be performed ONLY by qualified service personnel.</p>	
<small>W549</small>	

	WARNING
<p>To AVOID possible serious injury, BEFORE maintenance or repair tasks:</p> <ul style="list-style-type: none">• Disconnect all utilities such as gas, steam, and electricity. <p>Allow heated parts and surfaces to cool.</p>	
<small>W544</small>	

IMPORTANT: ALL maintenance must **ALWAYS** be carried out when the finisher is stopped, the cylinder is cold, and the circuit breaker is in position 0 (OFF).

Feeding Ribbons Tension Adjustment

To adjust the tension of the feeding ribbons, follow these steps and refer to *Figure 18*.

1. Loosen the screws at both ends of the pick-up table.
2. Carefully slide the pick-up table to adjust the tension of the feeding ribbons.

NOTE: The feeding ribbons should wrap around the feeding ribbon roller with enough tension to turn without sliding, but not so tight as to become stretched out.

3. When the correct tension has been reached, tighten the screws.

IMPORTANT: Do not over-tighten the feeding ribbons as this will cause rapid deterioration.

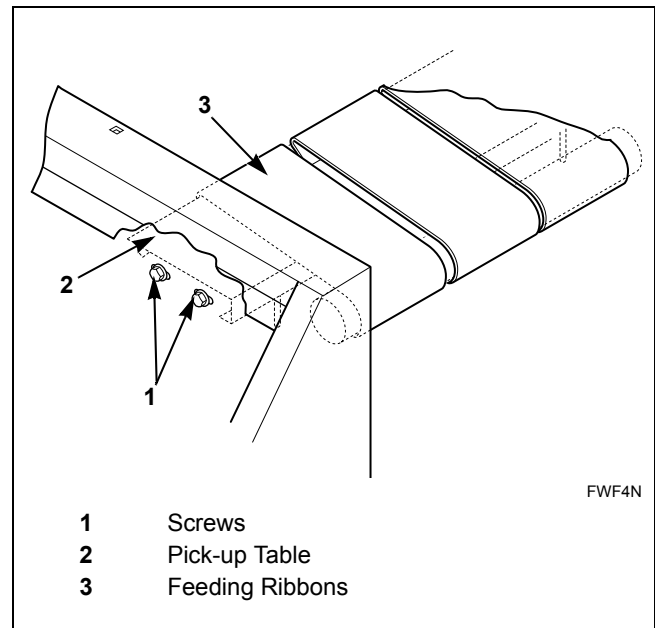

Figure 18

Return Ribbon Tension Adjustment

Tension of the return ribbons must be adjusted on both sides of the finisher. To adjust the tension of the return ribbons, follow these steps and refer to *Figure 19*.

1. Remove both side panels from the finisher.
2. Locate the return ribbon tension systems on each side of the finisher.
3. On one side of the finisher, unhook the tension spring from the tension pin.
4. Slide the tension pin out of the holes on the tension bracket.
5. Move the tension pin to another set of holes higher or lower on the tension bracket to adjust the tension of the return ribbons.

NOTE: The return ribbons should have enough tension to travel along the cylinder without slipping (including while carrying linen) but not so tight as to become stretched out.

6. Hook the tension spring back onto the tension pin.
7. Make an equal adjustment to the return ribbon tension system on the other side of the finisher.

NOTE: Count the number of holes on each tension bracket to verify that the tension of the return ribbons is equal on both sides of the finisher.

8. Replace both side panels on the finisher.

IMPORTANT: Do not over-tighten the return ribbons as this will cause rapid deterioration.

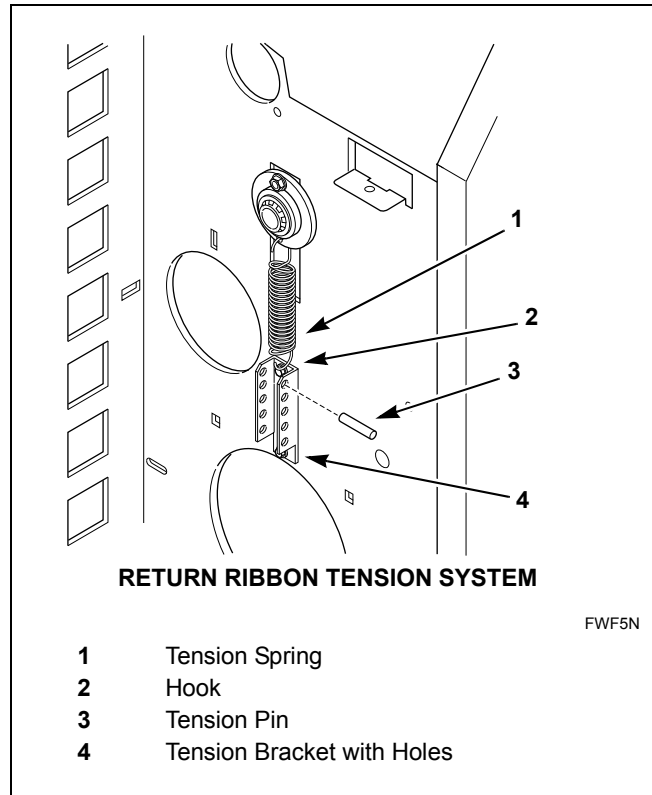

Figure 19

Press-Roller Pressure Adjustment

Tension of the press-roller must be adjusted on both sides of the finisher to adjust the pressure of the press-roller. To adjust the tension of the press-roller, follow these steps and refer to *Figure 20*.

1. Remove both side panels from the finisher.
2. Locate the press-roller tension systems on each side of the finisher.
3. On one side of the finisher, unhook the tension spring from the tension pin.
4. Slide the tension pin out of the holes on the tension bracket.
5. Move the tension pin to another set of holes higher or lower on the tension bracket to adjust the tension of the press-roller.

NOTE: The press-roller should have enough tension to allow it to slightly touch the cylinder for effective ironing but not so much tension that it applies excessive pressure on the cylinder.

6. Hook the tension spring back onto the tension pin.
7. Make an equal adjustment to the press-roller tension system on the other side of the finisher.

NOTE: Count the number of holes on each tension bracket to verify that the tension of the press-roller is equal on both sides of the finisher.

8. Replace both side panels on the finisher.

Press-Roller Drive Chain Tension Adjustment

To adjust the tension of the driving chain, follow these steps and refer to *Figure 20*.

1. Remove the right side panel from the finisher.
2. Locate the press-roller drive chain and the drive-roller sprocket.
3. Move the adjustable drive-roller sprocket along its rail to increase tension of the press-roller drive chain.

NOTE: The press-roller drive chain should have approximately 1.13 inches (29 mm) of freeplay.

4. Replace the right side panel on the finisher.

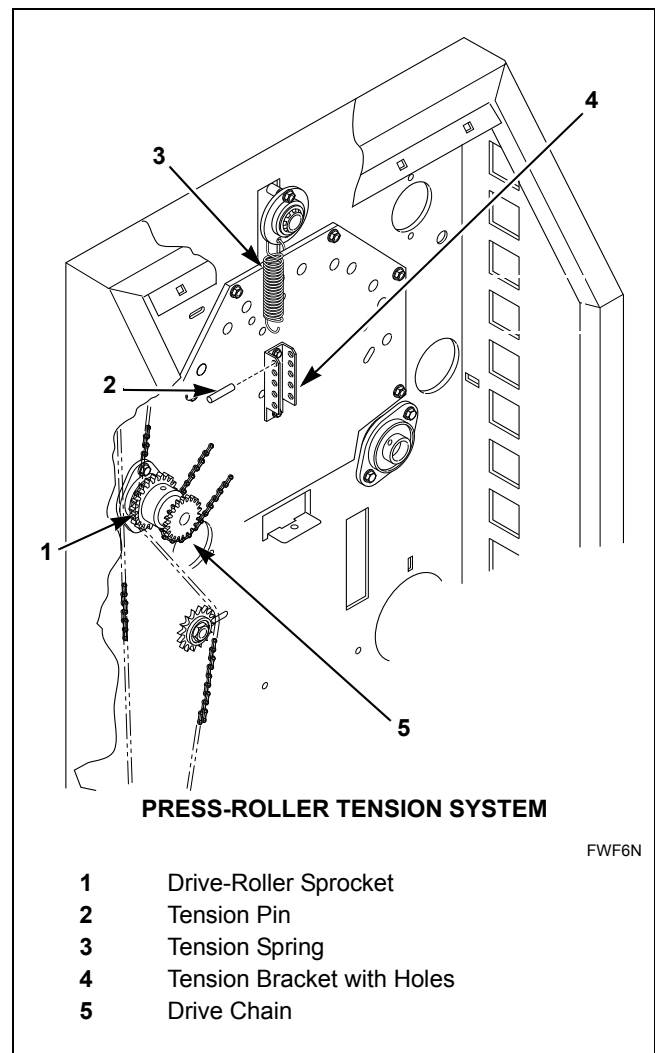

Figure 20

Thermostat Inspection

To clean the thermostat and its surrounding area, follow these steps and refer to *Figure 21*.

1. Gently press on the thermostat holder so the thermostat lifts up.
2. Rotate the thermostat holder 90 degrees.
3. Clean the thermostat holder if debris is present.
4. Clean the inside surface of the thermostat and its surrounding area if debris is present.
5. Place the thermostat holder back in its original position so the thermostat is touching the cylinder.

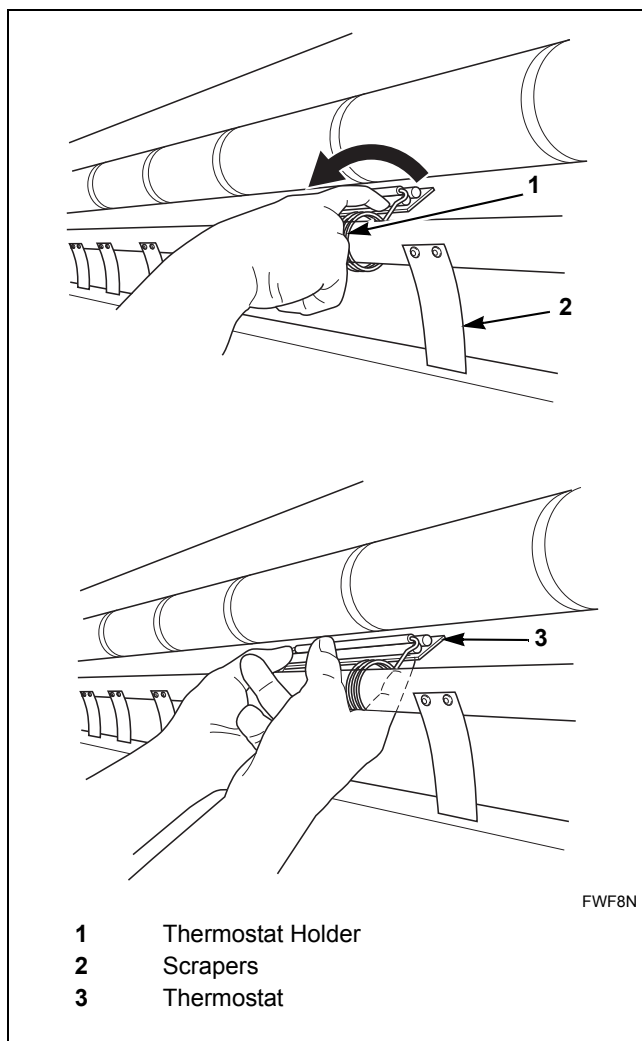

Figure 21

Cleaning the Scrapers

To clean the scrapers that guide the linen from the ironing cylinder into the output tray, use clean hands to gently wipe off any debris. Refer to *Figure 21*.

Waxing the Ironing Cylinder

IMPORTANT: If the finisher will not be used for more than a week, the ironing cylinder must be coated with paraffin wax to prevent it from rusting.

To coat the ironing cylinder with paraffin wax, follow these steps and refer to *Figure 22*.

1. Turn off the heat and proceed while the ironing cylinder is still warm.
2. Use a 5 mm Allen wrench to remove the top panel from the finisher.
3. Rotate the ironing cylinder at low speed.
4. Carefully hold a block of paraffin wax against one end of the cylinder and slowly move it along the length of the cylinder toward the other end.
5. Continue to apply the wax from one end of the cylinder to the other until the entire cylinder has an even coat of paraffin wax.
6. Stop the finisher.
7. Replace the top panel on the finisher.

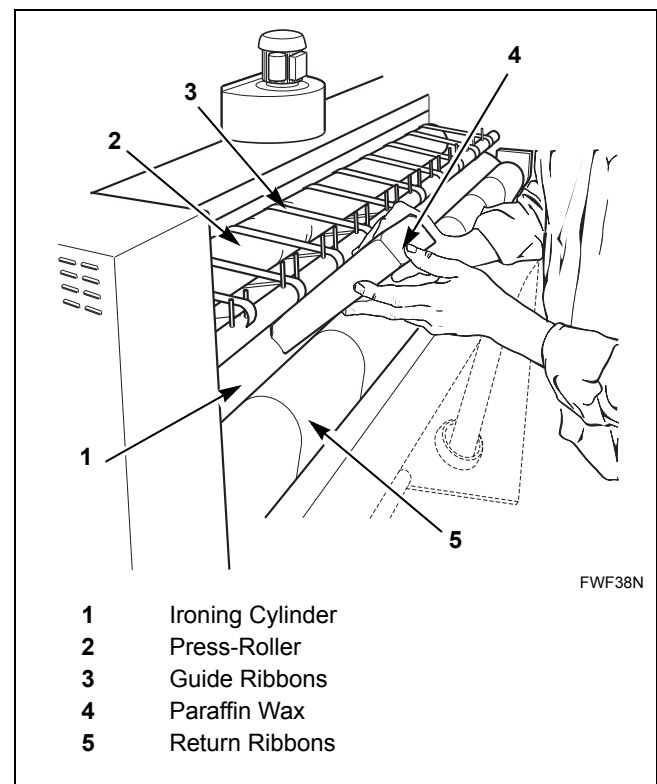

Figure 22

Maintenance

Removing Rust From Ironing Cylinder

If the ironing cylinder sits idle for more than a week without being coated with paraffin wax, it may become rusted.

To remove rust from the ironing cylinder, follow these steps.

1. Remove a couple return ribbons.
2. Sand the rusty area.
3. Reinstall return ribbons.
4. Repeat steps 1-3 and continue down the cylinder until all rusty surfaces have been sanded.

IMPORTANT: To prevent rust from returning, coat cylinder with paraffin wax.

Periodic Maintenance

Daily

Inspect (Before Start-Up)

Inspect the area between the thermostat holder and the cylinder and clean area if debris is present. Refer to *Figure 21*.

Inspect the thermostat holder and make sure it is touching the cylinder. Refer to *Figure 21*.

Weekly

Inspect (Before Start-Up)

Inspect the safety labels on the finisher and replace labels that are damaged, missing, or unreadable. Refer to the parts manual for ordering information.

Remove top panel and inspect the guide ribbons. Replace any missing ribbons. Refer to the parts manual for ordering information. The ribbons must be fitted loosely.

Every 200 Hours

Inspect (Before Start-Up)

Inspect the feeding ribbons for missing ribbons, and replace any ribbons that are missing. Refer to the parts manual for ordering information.

Inspect the feeding ribbons for the correct tension. They must be lightly stretched and wrapped around the feeding ribbon roller with no slippage. Refer to *Figure 18* and follow the procedures to adjust the tension of the feeding ribbons.

Inspect the return ribbons for the correct tension. The strips tend to lengthen slightly, especially during initial usage. Refer to *Figure 19* and follow the procedures to adjust the tension on the return ribbons.

Inspect the press-roller drive chain (on the right side of the machine) for the correct tension. The chain must not vibrate as it may then come loose. Refer to *Figure 20* and follow the procedure to adjust the tension of the press-roller drive chain.

Inspect the press-roller for the correct pressure. The press-roller must slightly touch the ironing cylinder without exerting too much pressure on the ironing cylinder. Refer to *Figure 20* and follow the procedures to adjust the pressure of the press-roller.

Inspect the vapor exhaust outlet and duct for debris. If debris is present, clean the vapor exhaust system.

Inspect the supporting rollers. There are four rollers that support the heated roll. These are located at bottom of heated roll, right and left side. Inspect for wear, replace when necessary.

Clean

Clean the finisher's exhaust system, including fans, fan cage, and exhaust outlet.

Clean the ventilation grids of the fan motor and drive motor.

Clean the ironing cylinder. Make sure to remove any detergent residue.

Clean the scrapers that guide the linen from the ironing cylinder into the output tray. Refer to *Figure 21*.

Vacuum the entire ironer. Remove top, side and front panels and remove any lint that may accumulate.

Grease

Grease the drive roller bearing with a high-temperature grease while rotating the ironing cylinder by hand.

Grease the motor chain and sprockets.

Grease the press-roller drive chain and sprockets.

Replacement of Feeding Ribbons

To replace the feeding ribbons, perform the following steps.

1. With a standard screwdriver, pop clamp open at left end of feeding roller. Refer to *Figure 23*.

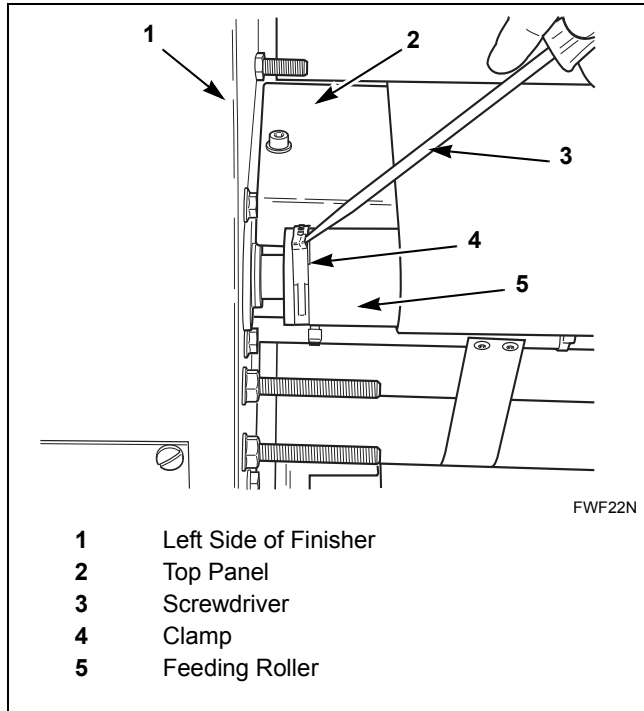

Figure 23

2. Remove clamp from roll.

3. Peel back adhesive strip from left side of feeding roller to expose roller pin. Refer to *Figure 24*.

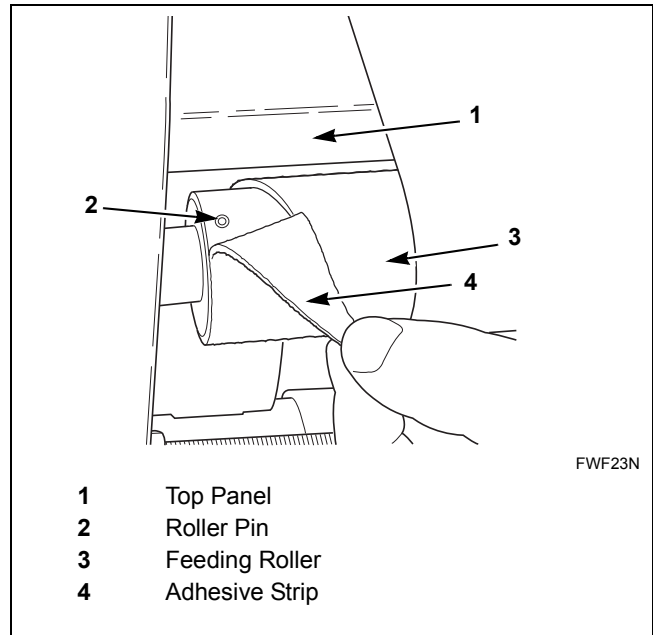

Figure 24

4. Using a center punch, completely knock out feeding roller pin. Refer to *Figure 25*.

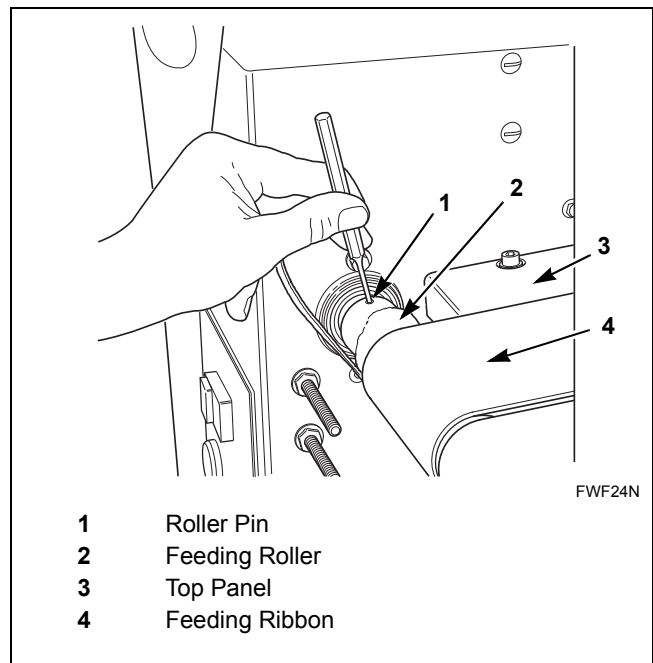

Figure 25

Maintenance

- Remove screw from left side of top panel (behind feeding roller). Refer to *Figure 26*.

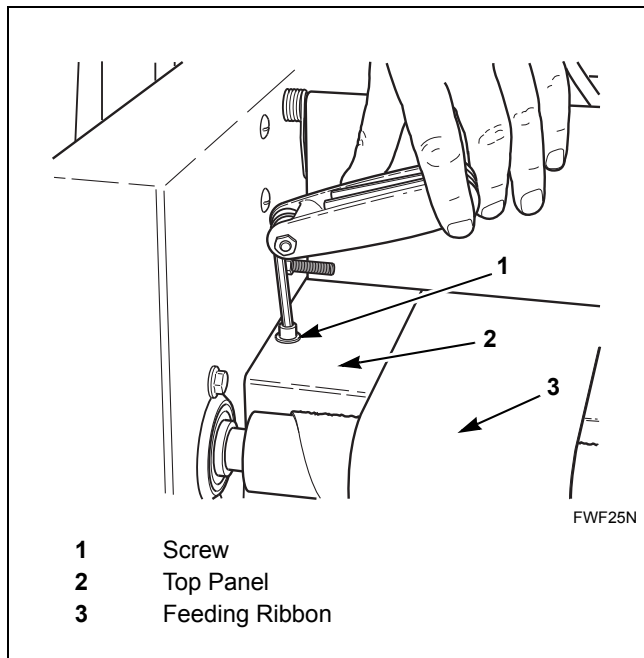

Figure 26

- Unlock the feeding ribbon roller at the left side interior panel by removing two screws. Keep roller in place and check the direction in which the bearing is mounted. Refer to *Figure 27*.

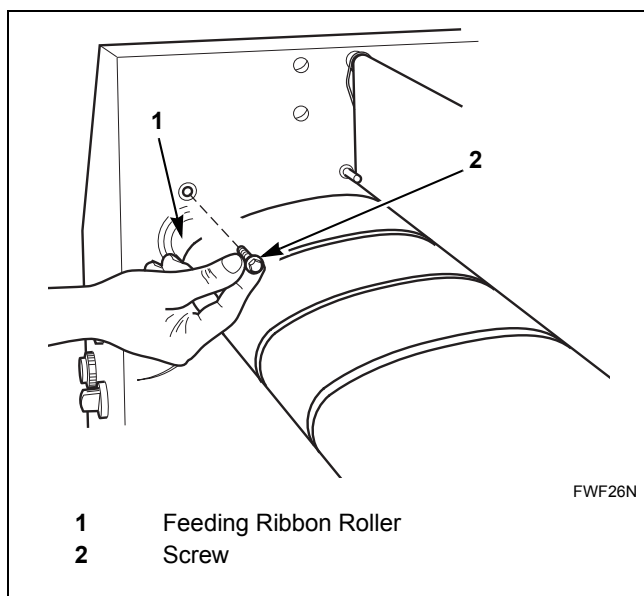

Figure 27

- Remove bearing by pressing left. Refer to *Figure 28*.

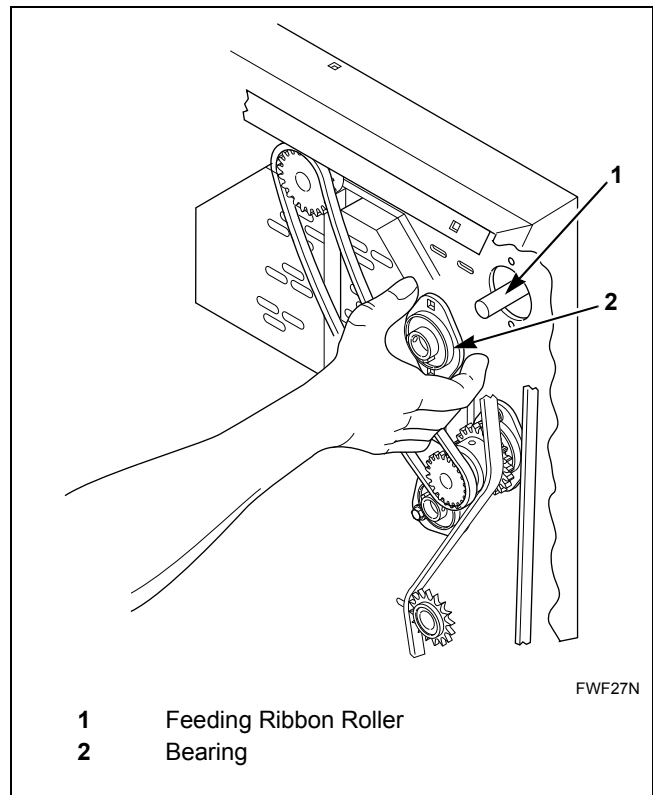

Figure 28

- Remove feeding ribbons by sliding to left side of roller.
- Replace feeding ribbons by sliding from left side of roller to right side.

NOTE: The feeding ribbons must be replaced by a complete new set of feeding ribbons.

- Install shaft by pressing right, making sure that shaft is in same direction as when it was removed.
- Reinstall two screws to left side interior panel.
- Reinstall screw to left side of top panel.
- Reinstall feeding roll pin.
- Glue adhesive strip back onto feeding roll with neoprene glue.
- Install new clamp onto feeding roll.
- Verify that the distance between the end of the input table and the cylinder is between 1/5 inch (5 mm) and 1/4 inch (6 mm).

NOTE: The gap between the feeding ribbons and cylinder must be at least 1/5 inch (5 mm).

Replacement of Return Ribbons

To replace return ribbons, perform the following steps.

1. Remove both side panels from the finisher.
2. Locate the return ribbon tension systems on each side of the finisher. Refer to *Figure 29*.
3. Remove tension screw and bracket from tension spring on each side of finisher.

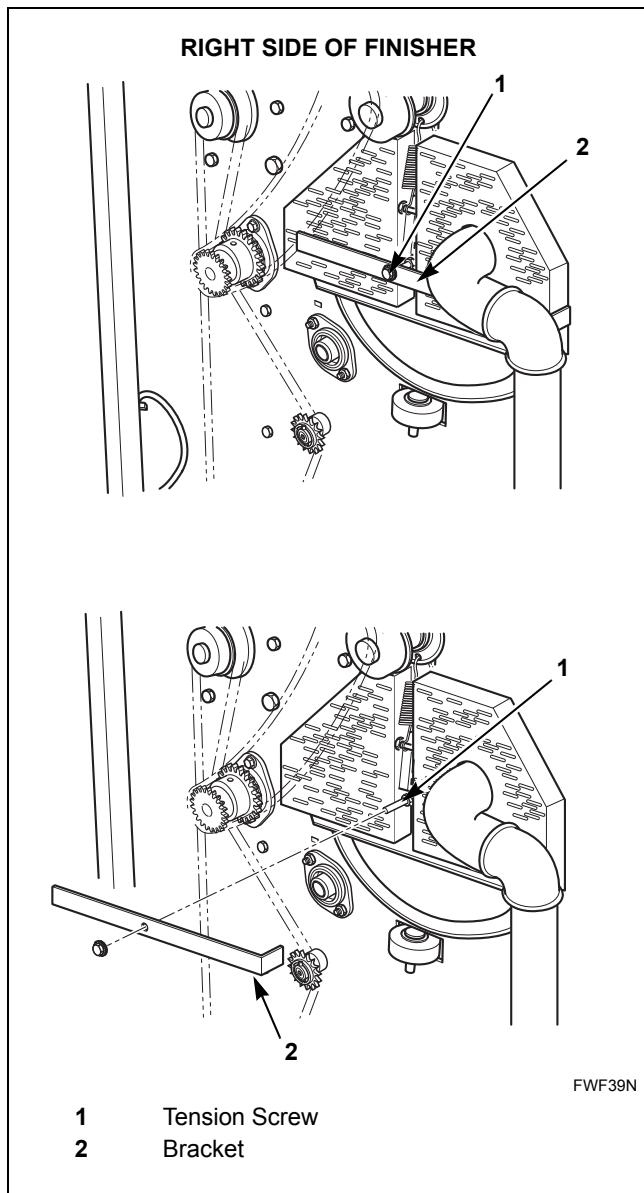

Figure 29

4. Unhook the return ribbon tension spring from the tension pin on each side of finisher. Refer to *Figure 30*.

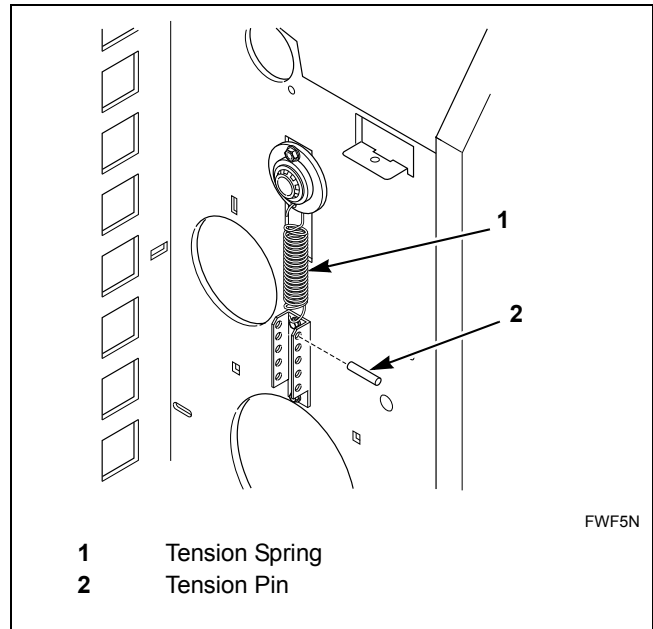

Figure 30

Maintenance

5. Remove rear panel from finisher.
6. Use manual crank to move cylinder until return ribbon connection point is at top of rear drive roller.
7. Remove pin from teeth of return ribbon. Refer to *Figure 31*.

NOTE: Do not release bottom portion of return ribbon.

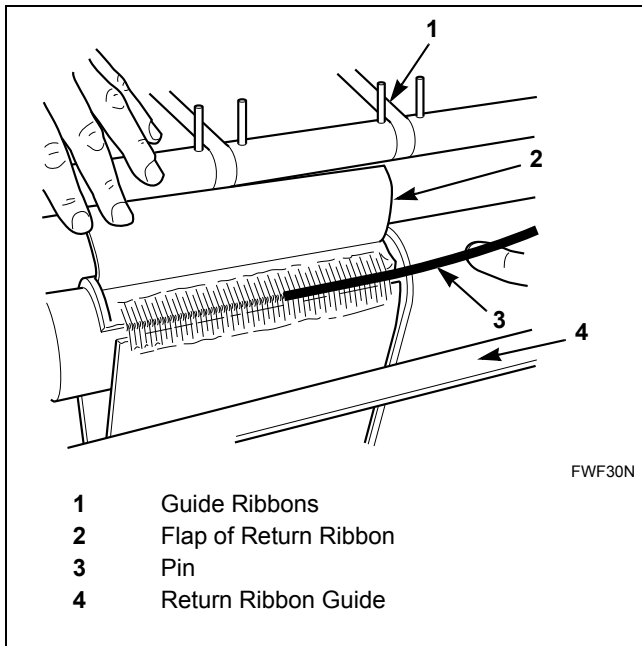

Figure 31

8. Install new return ribbon by connecting teeth from flap portion of new return ribbon to teeth of bottom (non-flap) portion on old return ribbon with pin.

NOTE: Be certain to keep return ribbon under return ribbon guide.

9. Use manual crank to turn cylinder until new return ribbon has completed the entire rotation of the cylinder.
10. Remove pin from teeth of return ribbons.
11. Connect both ends of new return ribbon by connecting teeth with pin.
12. Use manual crank to turn cylinder until correct tension of return ribbon is complete.

13. Verify that new return ribbon is placed in between the guide pins of output tray in front of machine. Refer to *Figure 32*.

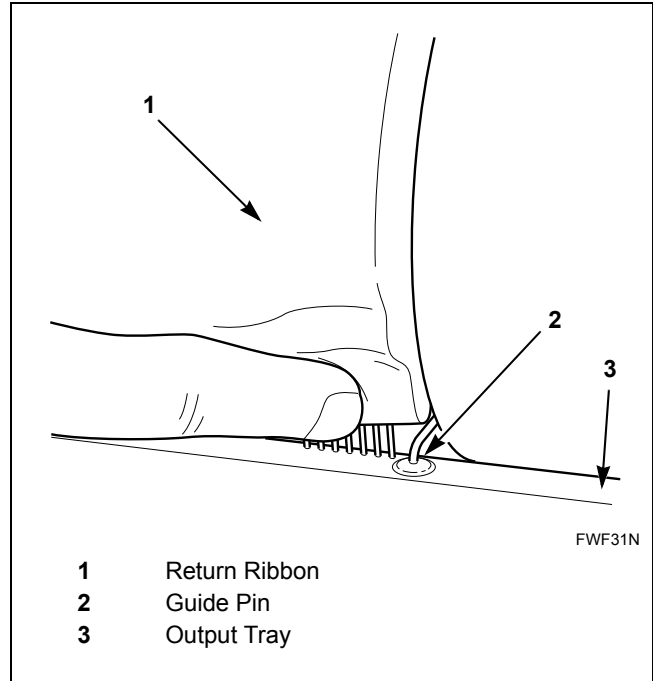

Figure 32

14. Hook the tension spring back onto the tension pin.
15. If necessary to increase or decrease the tension of the return ribbons, refer to *Adjustment of Return Ribbons* section.

NOTE: The return ribbons should have enough tension to travel along the cylinder without slipping (including while carrying linen) but not so tight as to become stretched out.

16. Reinstall rear panel.
17. Reinstall both side panels on the finisher.

Replacement of Supporting Rollers

To replace the supporting rollers, perform the following steps.

1. Remove side panels.
2. Remove top panel.
3. Lift the cylinder using a jack or maintenance crane.
4. Unscrew the blocking screws of the supporting rollers on the bar that carries the rollers (2 pointed screws).
5. Remove the bar and rollers.
6. Mount the bar back into place with new rollers.
7. Install the rollers in position on the bar, maintaining proper distances.
8. Install the bar on the straight blocks.
9. Reinstall top panel.
10. Reinstall side panels.

Replacement of Side Rollers

To replace side rollers, perform the following steps.

1. Remove side panels.
2. Remove screws that hold roller in place.
3. Remove spacer from old roller.
4. Place new roller onto spacer.
5. Install new roller in place with screws removed in step 2.
6. Reinstall side panels.

Troubleshooting Undesirable Finishes

Problem:	Possible Causes/Corrective Action:
Wrinkles in the fabric are not removed.	There is not enough moisture in the fabric. Dry fabric cannot be ironed. See chart below for moisture retention.
The fabric is not completely dry.	<ol style="list-style-type: none"> 1. The roll temperature is too low. Try a higher temperature, but do not exceed the maximum temperature tolerance of the most sensitive fiber. 2. The feed speed is too fast. Adjust the speed so the fabric is dry after one pass. 3. The fabric moisture content is too high. <ol style="list-style-type: none"> a. Provide a longer washer extraction time. b. Provide a higher washer g-force extraction speed. c. Partially dry (in a tumbler) the linen before finishing.
There are lengthwise wrinkles in the fabric.	The operators must stretch the fabric side to side during the feed process.
There are crosswise wrinkles in the fabric.	<p>The return ribbon travel is uneven.</p> <ol style="list-style-type: none"> 1. The return drive roll could be slipping on the ribbons. This could be caused by the presence of fabric softener on the roll. Fabric softener should not be used on fabrics that will be ironed. 2. The ribbon length is uneven. Uneven length ribbons will not drive the roll evenly.
Only a few articles can be ironed before the finish quality deteriorates. The operators must wait a few minutes before proceeding in order to process linen to the proper finish.	<ol style="list-style-type: none"> 1. There is too much water in the fabric. Large articles with excessive water content will remove a great amount of heat from the roll or shoe. This will reduce the roll or shoe temperature below that required to obtain an acceptable dry and finish. In order to compensate the operators may set the temperature too high. This may scorch the first items and can also damage the mechanical and electrical systems of the finisher. 2. The feeder speed is too fast. Slow down the feed speed.
There is color or staining on the finished material.	The wash process has not cleaned the fabric. Impurities such as soil, minerals, sour or detergent may still be present in the fabric. Since only the water is removed from the fabric during the finishing process, any impurities will remain as a deposit on the linen or finisher surfaces.
The fabric is scorched.	<p>The roll or shoe temperature is too high. Reduce the temperature.</p> <p>NOTE: The entire width of the finisher should be used to prevent overheating the unused surface. Small articles should be processed in a pattern that utilizes the entire width.</p>

Moisture Retention of Fabric	
Material Type	Moisture Retention
Synthetic Fibers	10-15%
Artificial silks, acetate and acetate fiber	10-15%
Rayon	10-15%
Silk	10-15%
Wool (iron between moist cloth)	10-15%

Polyester	10-15%
Poly-Cotton Blend	20-25%
Cotton	40-45%

